

# Have a Cuppa

Designed by Debby Kratovil

Featuring International Coffee by Whistler Studios

SIZE: 35" x 35"



FREE  
PROJECT

**THIS IS A DIGITAL REPRESENTATION OF THE QUILT TOP, FABRIC MAY VARY.**

**PLEASE NOTE:** BEFORE MAKING YOUR PROJECT, CHECK FOR ANY PATTERN UPDATES AT [WINDHAMFABRICS.COM](http://WINDHAMFABRICS.COM)'S FREE PROJECTS SECTION.



# Have a Cuppa

KEY	FABRIC	SKU	YD	CUTTING INSTRUCTIONS
A		43258-X Multi	5/8	Four border strips 4 1/2" x 27 1/2"
B		43263-1 Brown	Fat 1/8	Four 4-1/2" x wof strips for the border.
C		43263-5 Olive	Fat 1/8	Two 1-1/2" x wof strips. Recut into four 1-1/2" x 5-1/2" strips and four 1-1/2" x 7-1/2" strips (for alternate blocks).
D		43261-2 Gold	Fat 1/8	For foundation piecing the coffee cups.
E		43261-4 Cream	Fat 1/8	For foundation piecing the coffee cups.
F		43259-2 Gold	1/4	Four squares 5-1/2" x 5-1/2"
G		43262-4 Cream	1/3	Four 1-1/2" x 21-1/2" strips for the borders. Use the remainder for paper piecing the coffee cup blocks.
H		43262-2 Gold	1/3	8 strips 1-1/2" x 21-1/2" (border strips). Also cut 16 squares 1-1/2" x 1-1/2" (border 9 Patch blocks). Use the remainder for paper piecing the coffee cup blocks.
I		43263-3 Wine	1/2	Two 1-1/2" x wof strips. Recut into four 1-1/2" x 5-1/2" strips and four 1-1/2" x 7-1/2" strips (for alternate blocks). Also cut four 4-1/2" squares (border squares) and twenty 1-1/2" squares from two 1-1/2" x wof strips (border 9 Patch blocks). Cut four 2-1/4" strips for binding. Use the remainder to paper piece the coffee cup blocks.
J		43260-4 Cream	1 1/4	Backing
				Fusible webbing for coffee cup handles
				40" x 40" square of batting





# Have a Cuppa

**Sewing:**

1. Piece the four alternate blocks as shown in Diagram 1 using the four 5-1/2" print squares and the red and green 1-1/2" strips.

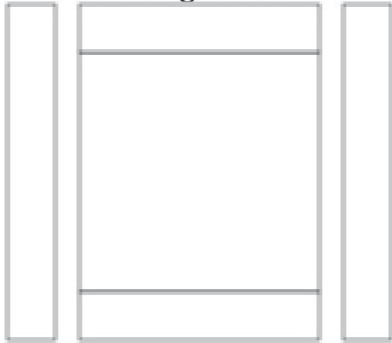

Diagram 1: Make 4

2. Use remaining fabrics to foundation piece the coffee cups. Machine applique the coffee cup handles last. Blocks measure 7-1/2" unfinished. Diagrams 2-5 show the number of blocks to make using the various patterns.

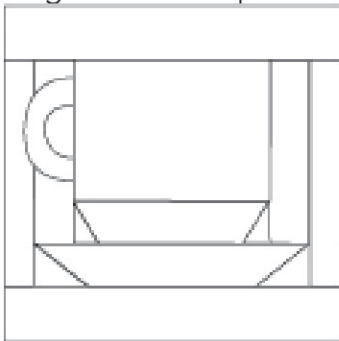

Diagram 2: Make 1

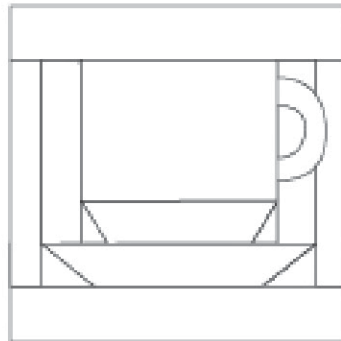

Diagram 3: Make 2

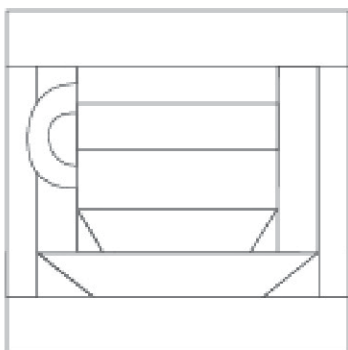

Diagram 4: Make 1

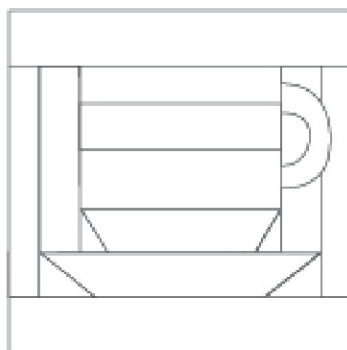

Diagram 5: Make 1



# Have a Cuppa

3. Join the four Alternate Blocks and the five Coffee Cups blocks into the quilt center as shown in the quilt picture. They are sewn block to block. Press seams open for reduced bulk.
4. Sew the triple sashings using the gold and cream 1-1/2" x 21-1/2" strips. Sew the four 9 Patch corner blocks using the red and gold 1-1/2" squares. Sew the 9 Patch blocks to the short ends of two border strips. See Quilt Assembly for placement.
5. Quilt Center now measures 27-1/2" x 27-1/2". Measure and cut four 4-1/2" border strips to this width and join two to quilt center. Sew a 9 Patch block to a short end of each of the two remaining border strips and add last two borders to quilt.

**Finishing:**

6. Layer quilt top, batting and backing and quilt as desired.
7. Sew the four 2-1/4" strips of the **H** fabric together into one long strips and use to bind quilt.



# Have a Cuppa

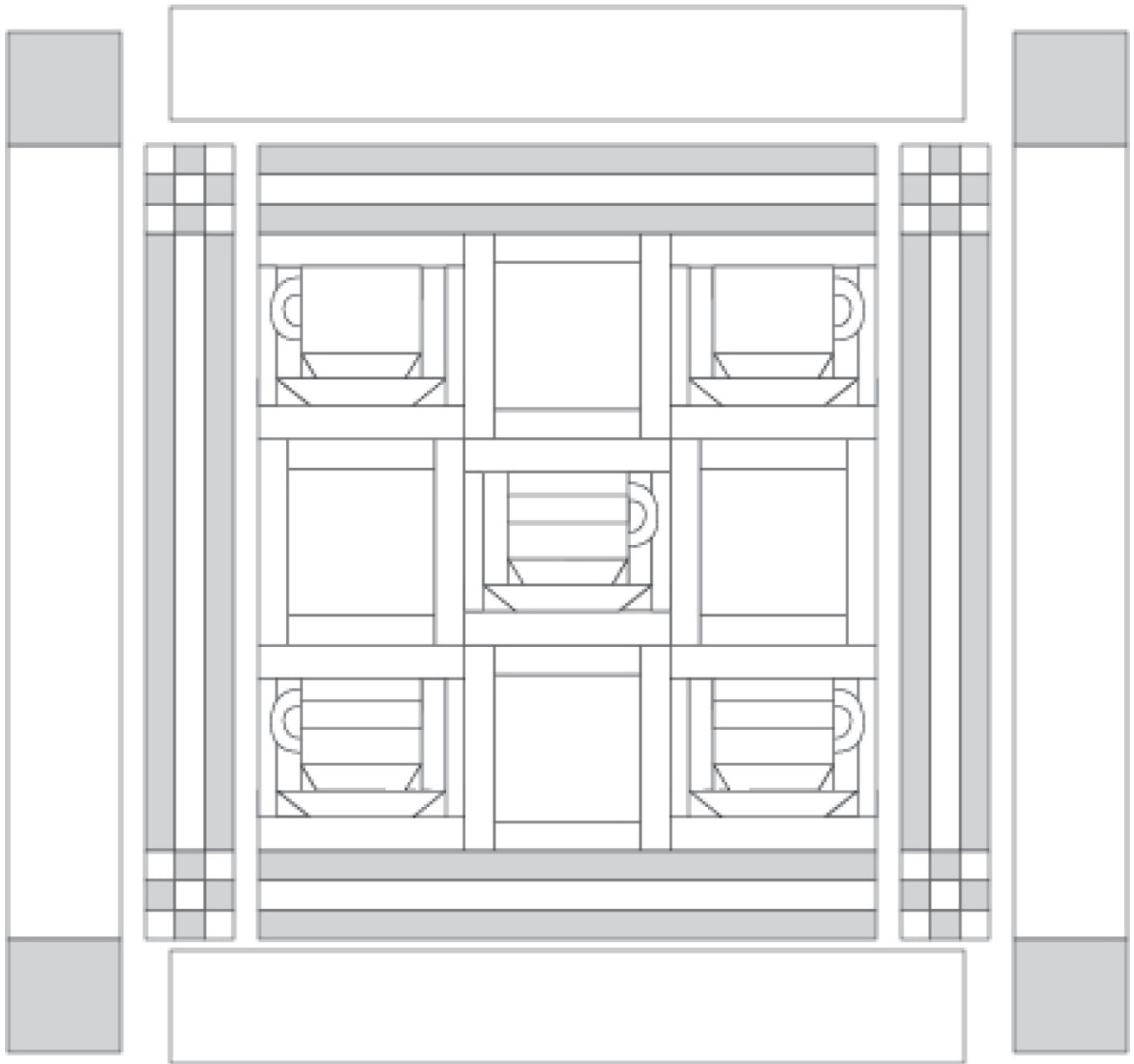

Quilt Assembly Diagram

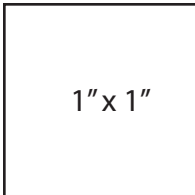

1" x 1"

# Coffee Cup #2© by Debby Kratovil

Block Size: 7" x 7" finished

This box measures 1" square. Check your printer's settings to make sure your copies are accurate based on this.

Cutting patch sizes appear in red; patches are cut oversized; you may increase these by 1/4 - 1/2"

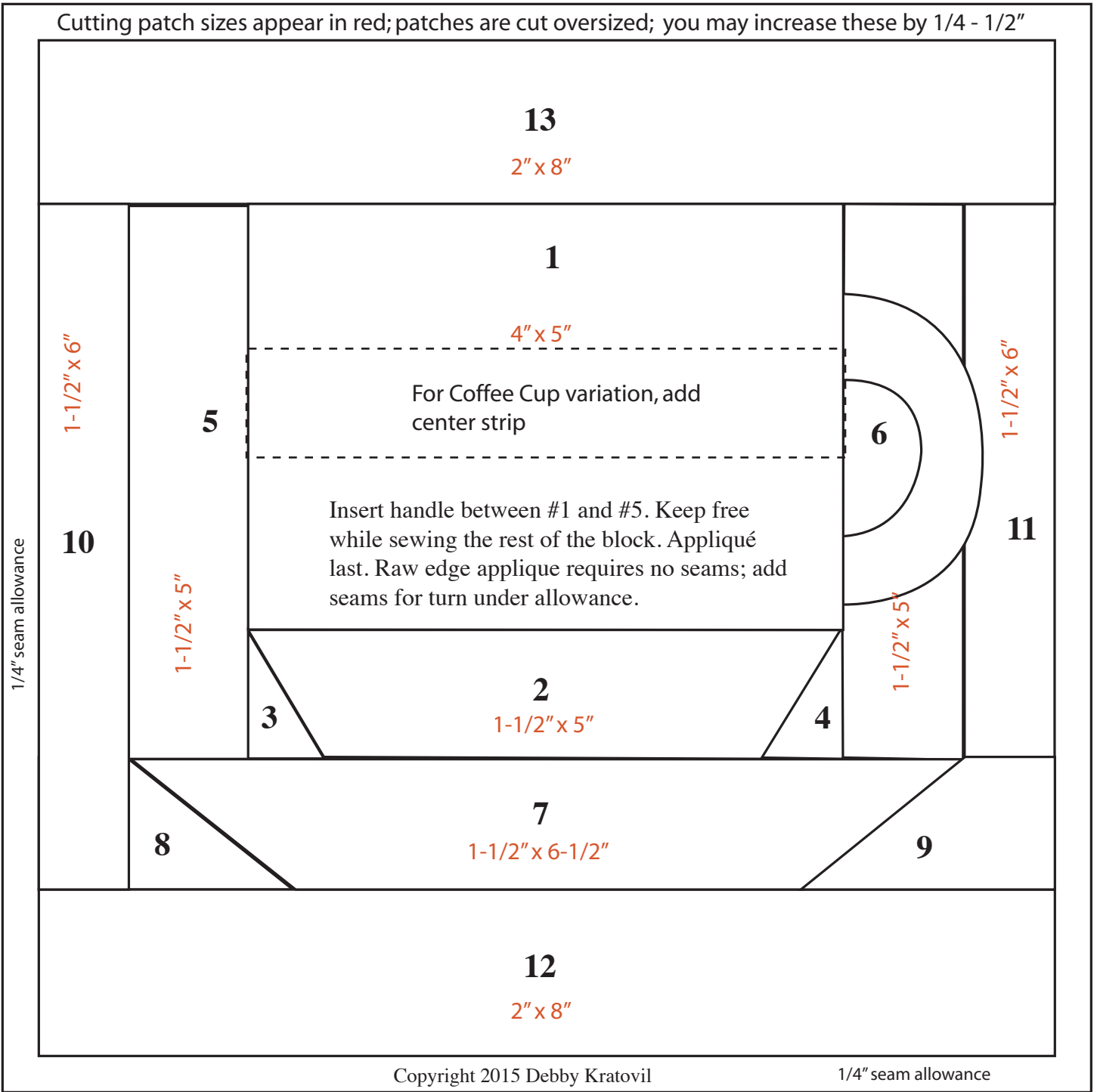

Copyright 2015 Debby Kratovil

1/4" seam allowance

IMPORTANT NOTE: Keep the cup handle free as you TRIM Patch #5 and also as you ADD Patch #10. And make sure, if using fusible webbing, you don't accidentally fuse it the entire width of Patch #5 before adding Patch #10. Believe me, I learned this the hard way and still had trouble remembering with each block!